

Intelligent CO₂ Sensor for Fermentation In-line, Fast and Simple



ISM technology

- Plug and Measure for seamless installation
- Pre batch diagnostics for best measurement performance
- Full traceability for complete documentation



High performance

- In-line measurement for real-time process control
- Reliable CO₂ measurement
- Fast response
- High signal stability thanks to new probe design



Easy handling

- Proven membrane body concept for low maintenance
- Only process calibration is needed



Hygienic design

- Fully SIP resistant and autoclavable
- Teflon coated membrane to avoid biofouling
- FDA compliant design and materials



InPro 5000 i – The most intelligent way to measure dissolved CO₂

The InPro 5000 i combines proven measurement technology based on the Severinghaus principle with Intelligent Sensor Management (ISM) to simplify CO₂ measurement.

The robust and fully sterilizable sensor design meets all requirements for hygienic processes.

ISM technology provides all sensor relevant information for maintenance planning, and pre-batch or real-time diagnostics. For full traceability, all pertinent data such as calibration details and number of SIP or autoclavings are stored inside the sensor.

Plug and Measure with factory-calibrated sensors sets a new benchmark in simplicity for in-line CO₂ measurement.

Technical data of the InPro 5000 i

| | |
|--|--|
| Measurement range | 10 to 1000 mbar CO ₂ |
| Accuracy | ± (10% of the reading + 10 mbar) |
| Operating temperature | 0 ... 60 °C (32 ... 140 °F) |
| Mechanical temperature resistance | -20 ... 130 °C (-4 ... 266 °F) |
| Operating pressure | 0.2 ... 2 bar (3 ... 30 psia) |
| Mechanical pressure resistance | Max. 3 bar (42 psia) at 25 °C (77 °F) |
| Steam sterilizable and autoclavable | Yes |
| Cable connection | AK 9 |
| O ₂ selective membrane material | Teflon/Silicone |
| Shaft diameter | 12 mm |
| Available lengths | 120 mm, 220 mm, 320 mm |
| Certificates | Quality certificate, Material certificate 3.1, Surface finish certificate 2.1, |
| Response time t ₉₀ at 25 °C (77 °F) | < 120s |

► www.mt.com/InPro5000i

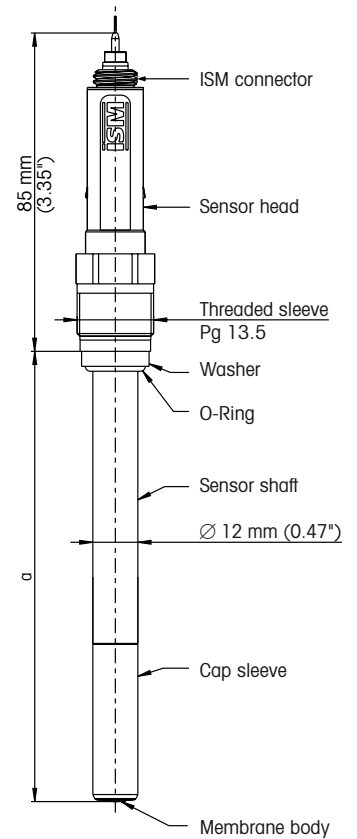

Additional information

| Designation | Compatible Transmitter | Suitable Housing |
|--------------|------------------------|--------------------|
| InPro 5000 i | M400 Type 3 | InFit 761 e |
| | M800 | InTrac 777 e/797 e |



Transmitters:
Multi-parameter transmitters leverage the full ISM functionality of the sensors for best process control and ease of use.



iSense Asset Suite
PC software tool to simplify calibration and documentation. iSense provides accurate pre-batch diagnostics for maximum reliability of the measurement.

www.mt.com/pro

For more information

Mettler-Toledo AG
Process Analytics
8902 Urdorf, Switzerland
Phone +41 44 729 62 11
Fax +41 44 729 66 36



Management System certified according to ISO 9001 / ISO 14001

Subject to technical changes.
© 01 / 2012 Mettler-Toledo AG.
Printed in Switzerland. 30 037 314

Sales and service: